

Interfar Wall Beds fold away easily leaving you with a lot of extra living space. So they're excellent for studio apartments, home offices, or simply making practical use of limited space.



FOLD DOWN DOOR WALL BEDS



In one easy motion, the fold down doors are swept away to reveal ultimate sleeping comfort. Using our unique counter-balance system you can adjust the bed tension for any mattress weight to ensure ease of operation.

Available in Single, Double and Queen sizes, in a selection of colours and finishes, the Fold Down System can be combined with our add on storage modules to create the ideal sleeping environment.

HORIZONTAL SINGLE



If you are restricted by wall height or require single sleeping only, then the Horizontal Single is the way to go. Light in weight and low in height. Great for children's rooms or small spaces. This compact bed folds back neatly into a stylish waist-high cabinet. Available in single size only.

BI – FOLD DOOR WALL BEDS



The Bi-Fold System combines mid-range pricing with a lightweight operation in a vertical slim-line cabinet. Just open the doors and easily lower the bed frame and mattress to the floor. Add on our storage modules to complete your multipurpose room.

BI - FOLD MECHANISM ONLY

Our Bi-Fold Mechanism is the ideal alternative when an existing cupboard or alcove is to be utilised and storage is not necessary. Available in Single, Double and Queen sizes every mechanism comes with a 5 year warranty and easy-to-follow installation instructions.



FOLD DOWN DOOR WALL BEDS

Dimension A

Single: 1024 | Double: 1524 | Queen: 1624

Dimension B

All Sizes: 2230

Dimensions C

Single: 2200 | Double: 2200 | Queen: 2350

Dimension D

All Sizes: 500

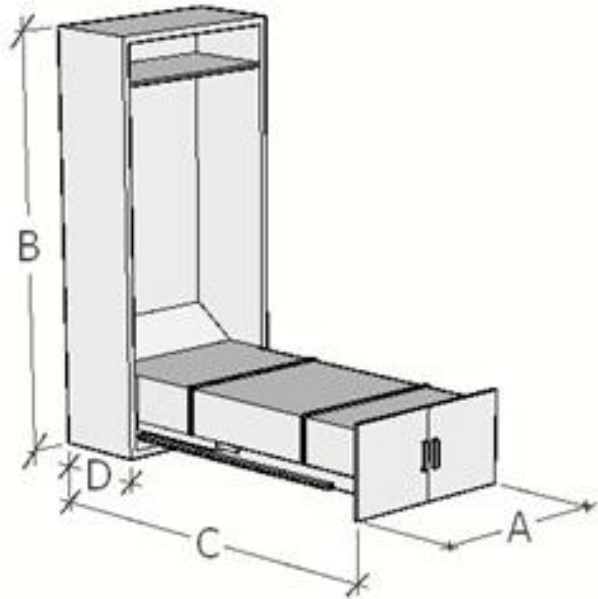

HORIZONTAL SINGLE

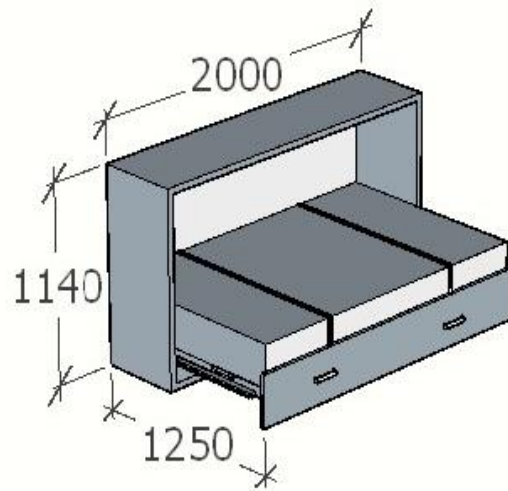

BI-FOLD DOOR WALL BEDS

Dimension A

Single: 1120 | Double: 1620 | Queen: 1720

Dimension B

All Sizes: 2230

Dimension C

Single: 2100 | Double: 2100 | Queen: 2250

Dimension D

All Sizes: 500

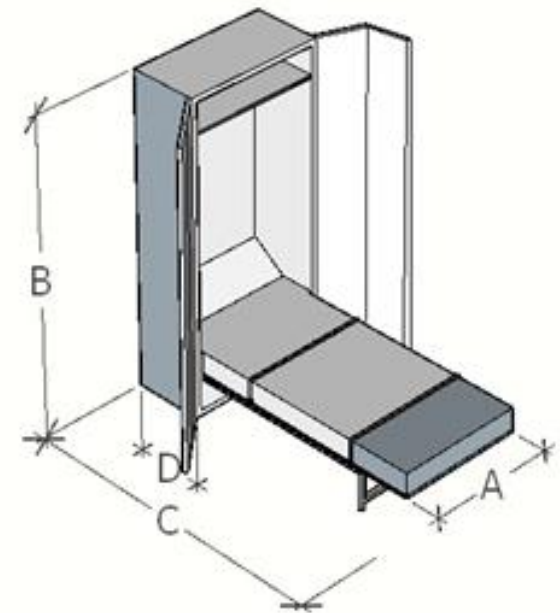

ADD ON STORAGE UNITS

Our add-on storage units have been designed to cater for all your storage requirements, with adjustable shelving, a unique hanging and pull out bedside table system and a choice of widths, you're sure to find a combination to suit your needs.

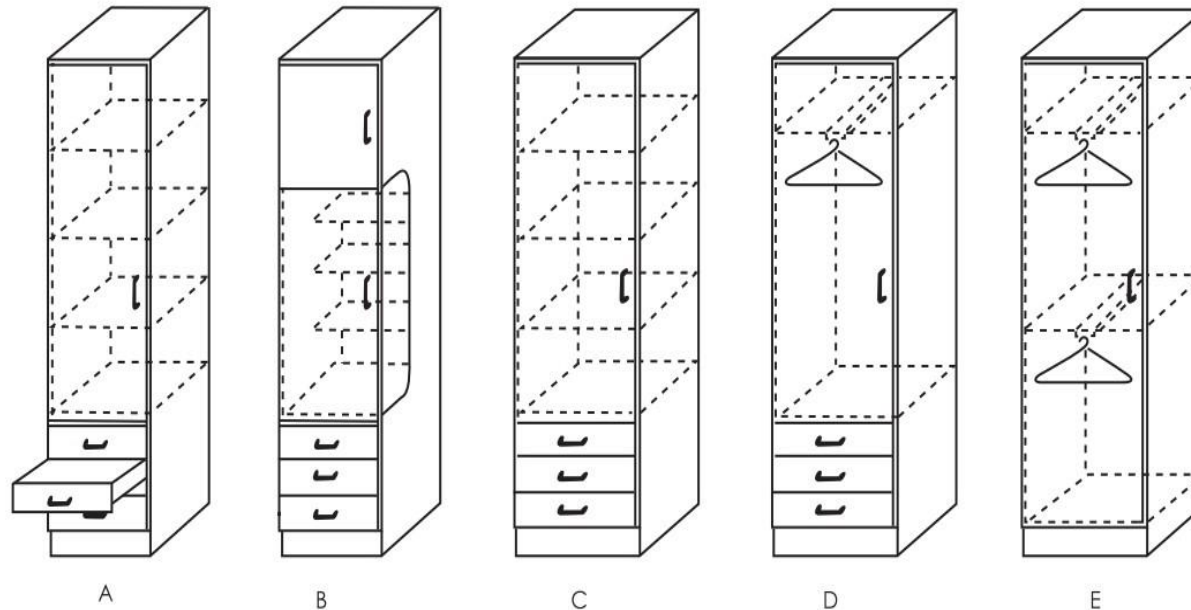

A, B & C 450 or 600 wide. D & E 600 wide only—height and depth match wall beds—modules available left or right hand.

IMPORTANT NOTES

BED FRAME: All wall bed frames feature cambered timber slat mattress supports which allow for the natural curve of the spine while resting. The slat supports are connected to a heavy duty steel frame by flexible support brackets.

MATTRESS: Standard innerspring mattresses are recommended. Maximum mattress thickness is 250mm.

CABINETS: All cabinets are manufactured in Australia using a selection of colours & finishes.

INSTALLATION: All cabinets must be fixed securely to the wall. Further fixing details provided on request.

OPERATION: All wall beds must be carefully lowered to the floor and not left to drop freely.



GALLERY

